

KATALÓG

**KOTVIACE PRVKY NA PLOCHÉ
STRECHY A OPLÁŠTENIA STAVIEB**

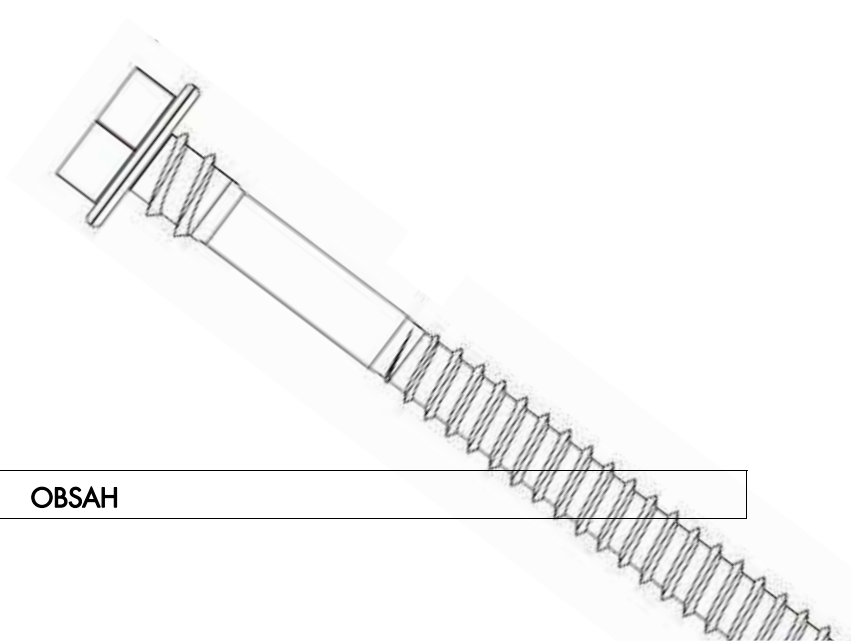

		Art.	Strana
Oceľ	SKRUTKA EDS - S	0838 642 xxx / 0838 648 xxx	1.01
	SKRUTKA EDS - B	0838 048 xxx	1.02
	SKRUTKA EDS - SRB	0838 148 xxx	1.03
	SKRUTKA EDS - BZT	0838 448 xxx	1.04
	SKRUTKA EDS - BGT	0838 548 xxx	1.05
	SKRUTKA EDS - BGTR	0838 748 xxx	1.06
	SKRUTKA EDS - TRPB	0838 045 xxx	1.07
	SKRUTKA EDS - TRPBG	0838 445 xxx	1.08
Drevo	SKRUTKA EDS - H	0838 150 xxx	1.20
	SKRUTKA DAMPH	0838 154 xxx	1.21
Porobetón	SKRUTKA GBS	0838 060 xxx	1.30
Betón	KLINEC ISPC	0838 050 xxx	1.40
	SKRUTKA EFHD	0838 163 xxx	1.41
Podložky	PODLOŽKA DVP SL	0838 080 xxx / 0838 087 xxx 0838 240 xxx / 0838 250 xxx	1.50
	PODLOŽKA DVP ML	0838 070 xxx	1.51
	PODLOŽKA DVP AUT	0838 080 xxx / 0838 707 xxx	1.52
	PODLOŽKA TLK-45	0838 245 xxx	1.53
	PODLOŽKA TLK-75	0838 275 xxx	1.54
OMG	SKRUTKA OMG RS	0838 355 xxx	1.60
	SKRUTKA OMG HD	0838 160 xxx	1.61
	SKRUTKA OMG XHD	0838 167 xxx	1.62
	SKRUTKA OMG RNH	0838 263 xxx	1.63
	KLINEC	0838 255 xxx	1.64
	PODLOŽKA OMG DVP	0838 051 xxx / 0838 063 xxx	1.65
	OMG GYPTEC	0838 018 xxx	1.66
Univerzálné	SDS-PLUS VRTAK	0838 6xx xxx	1.70
	PRÍSLUŠENSTVO	0838 xxx xxx	1.71

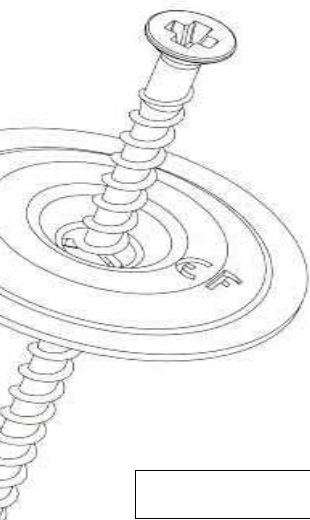

SKRUTKA EDS-S



MAGNI™
SILVER



Oceľ

≥ 0,70 ≤ 0,88 mm

0838 642 ...

0838 648 ...

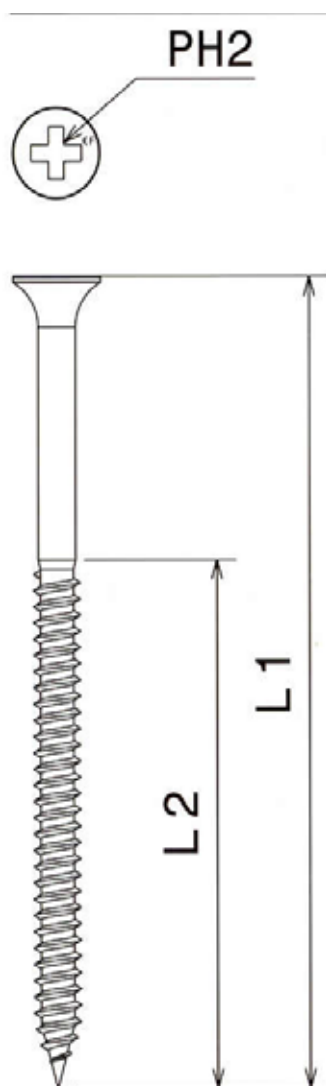

Art.	∅	L1	L2	Balenie
0838 642 025	4,2	25	20	1000
0838 642 035	4,2	35	30	1000
0838 642 045	4,2	45	40	1000
0838 642 055	4,2	55	50	1000
0838 642 065	4,2	65	55	1000
0838 642 075	4,2	75	60	1000
0838 648 050	4,8	50	45	1000
0838 648 060	4,8	60	50	500
0838 648 070	4,8	70	60	500
0838 648 080	4,8	80	70	500
0838 648 085	4,8	85	70	500
0838 648 090	4,8	90	80	500
0838 648 100	4,8	100	80	500
0838 648 110	4,8	110	80	500
0838 648 120	4,8	120	80	500
0838 648 130	4,8	130	80	500
0838 648 140	4,8	140	80	500
0838 648 150	4,8	150	80	500
0838 648 160	4,8	160	80	500
0838 648 170	4,8	170	80	500
0838 648 180	4,8	180	80	500
0838 648 200	4,8	200	80	500
0838 648 220	4,8	220	80	500
0838 648 240	4,8	240	80	500
0838 648 260	4,8	260	80	500
0838 648 280	4,8	280	80	500
0838 648 300	4,8	300	80	500

Technické údaje	Použitie do:	Podložka	Potrebná dĺžka
Skrutka, trubková hlava, tvrdý hrot, PH2, tvrdý hrot. Povrch: Magni-Silver, min. 15 cyklov Kesternich testu podľa DIN 50018 S2, OL	Profilový krycí plech od 0,70 mm do 0,88 mm	Kovová: (strana 1.50) Plastová: (strana 1.53/1.54)	Izolácia + min 20 mm

SKRUTKA EDS-B

0838 048 ...



MAGNI™
SILVER



Oceľ

≥ 0,88 - max 2 x 1,25 mm

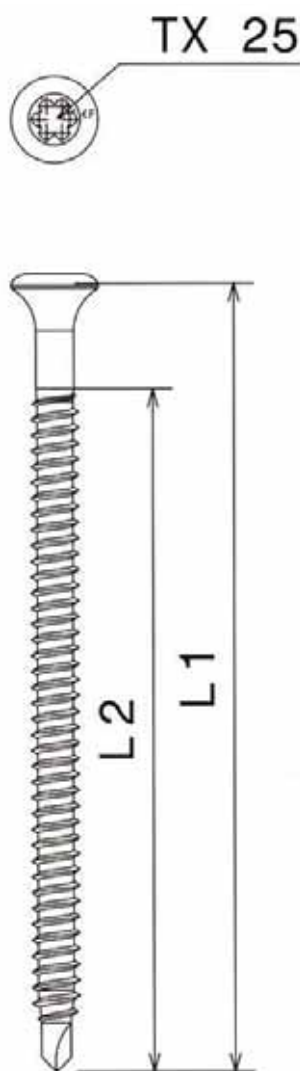

Art.	∅	L1	L2	Balenie
0838 048 035	4,8	35	35	1000
0838 048 050	4,8	50	50	1000
0838 048 060	4,8	60	50	1000
0838 048 070	4,8	70	50	1000
0838 048 080	4,8	80	50	1000
0838 048 090	4,8	90	50	1000
0838 048 100	4,8	100	80	500
0838 048 110	4,8	110	80	500
0838 048 120	4,8	120	80	500
0838 048 130	4,8	130	100	500
0838 048 140	4,8	140	100	500
0838 048 150	4,8	150	100	500
0838 048 180	4,8	180	120	500
0838 048 210	4,8	210	120	500
0838 048 240	4,8	240	120	500
0838 048 260	4,8	260	120	500
0838 048 280	4,8	280	120	500
0838 048 300	4,8	300	120	500

Technické údaje	Použitie do:	Podložka	Potrebná dĺžka
Skrutka, trubková hlava, redukovaný vrták, TX25. Povrch: Magni-Silver, min. 15 cyklov Kesternich testu podľa DIN 50018 S2, OL	Profilový krycí plech do 2 x 1,25 mm	Kovová: (strana 1.50) Plastová: (strana 1.53/1.54)	Izolácia + min 20 mm

SKRUTKA EDS-SRB

0838 148 ...



Bi-Metal
Zinc-plated



Oceľ

≥ 0,88 - max 2 x 1,25 mm

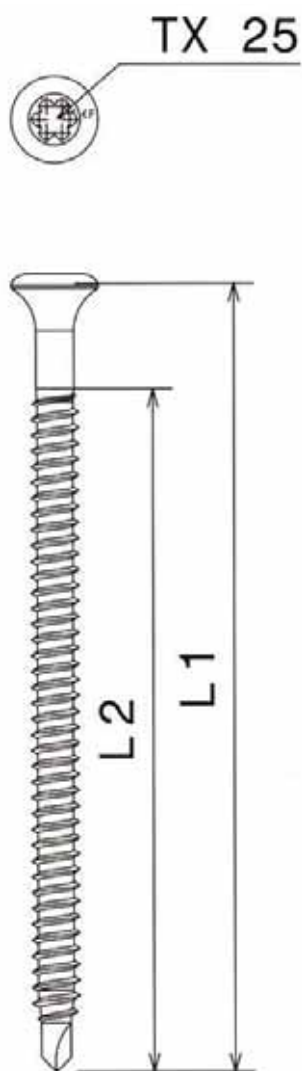

Art.	∅	L1	L2	Balenie
0838 148 060	4,8	60	50	500
0838 148 080	4,8	80	50	500
0838 148 100	4,8	100	50	500
0838 148 120	4,8	120	75	500
0838 148 140	4,8	140	75	500
0838 148 160	4,8	160	105	500
0838 148 180	4,8	180	120	500
0838 148 210	4,8	210	120	500
0838 148 240	4,8	240	120	500

Technické údaje	Použitie do:	Podložka	Potrebná dĺžka
Bi-metall, skrutka, trubková hlava, redukovaný vrtak, TX25. Povrch: pozinkovaný	Profilový krycí plech do 2 x 1,25 mm	Kovová: (strana 1.50) Plastová: (strana 1.53/1.54)	Izolácia + min 20 mm

SKRUTKA EDS-BZT



Oceľ

≥ 0,88 - max 2 x 1,25 mm

0838 448 ...

MAGNI™
SILVER

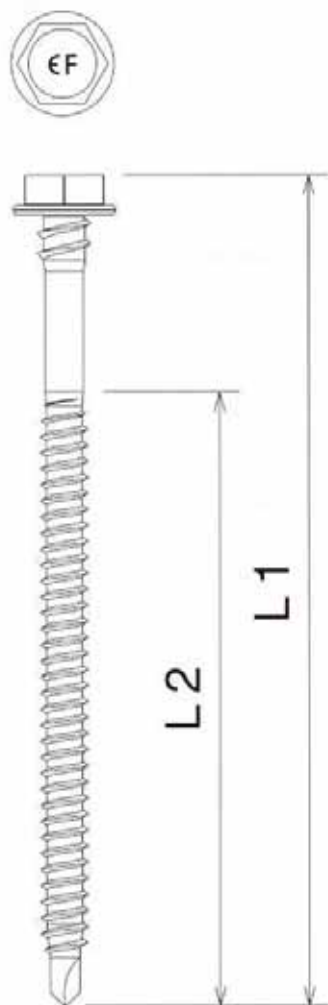

Art.	∅	L1	L2	Balenie
0838 448 070	4,8	70	50	500
0838 448 080	4,8	80	50	500
0838 448 090	4,8	90	50	500
0838 448 100	4,8	100	50	500
0838 448 120	4,8	120	75	500
0838 448 140	4,8	140	75	500
0838 448 160	4,8	160	105	500
0838 448 180	4,8	180	120	500
0838 448 200	4,8	200	120	500
0838 448 220	4,8	220	120	500
0838 448 240	4,8	240	120	500
0838 448 260	4,8	260	120	500
0838 448 280	4,8	280	120	500
0838 448 300	4,8	300	120	500

Technické údaje	Použitie do:	Podložka	Potrebná dĺžka
Skrutka, 6-hranná hlava SW8, redukovaný vrtak Povrch: Magni-silver, min. 15 cyklov Kesternich testu podľa DIN 50018 S2, OL	Profilový krycí plech do 2 x 1,25 mm	Kovová: (strana 1-50/1.51/1.52)	Izolácia + min 20 mm

SKRUTKA EDS-BGT

0838 548 ...



MAGNITM
SILVER



Oceľ

≥ 0,88 - max 2 x 1,25 mm

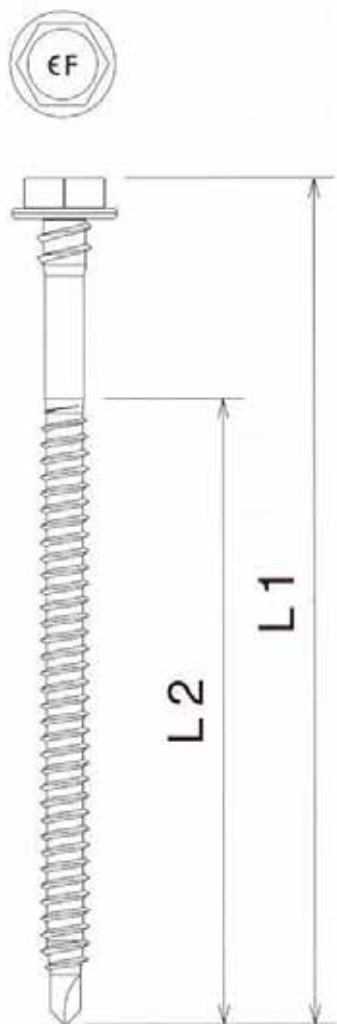

Art.	ø	L1	L2	Balenie
0838 548 070	4,8	70	50	1200
0838 548 080	4,8	80	50	1200
0838 548 090	4,8	90	50	1200
0838 548 100	4,8	100	50	1050
0838 548 120	4,8	120	75	1050
0838 548 140	4,8	140	75	750
0838 548 160	4,8	160	105	750
0838 548 180	4,8	180	120	750
0838 548 200	4,8	200	120	750
0838 548 220	4,8	220	120	750
0838 548 240	4,8	240	120	750

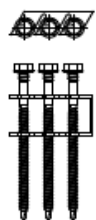

Technické údaje	Použitie do:	Podložka	Potrebná dĺžka
Skrutka, 6-hranná hlava SW8, redukovaný vrtak Povrch: Magni-silver, min. 15 cyklov Kesternich testu podľa DIN 50018 S2, OL	Profilový krycí plech do 2 x 1,25 mm	Kovová: (strana 1.52)	Izolácia + min 20 mm

SKRUTKA EDS-BGTR

0838 748 ...



Bi-Metal
Zinc-plated



Oceľ

≥ 0,88 - max 2 x 1,25 mm

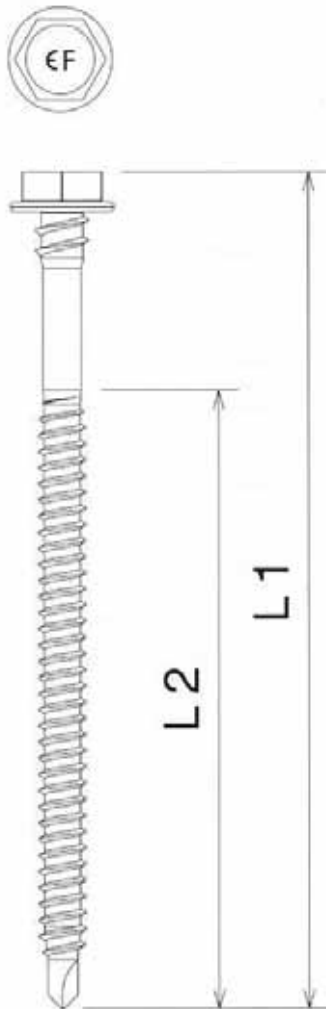

Art.	ø	L1	L2	Balenie
0838 748 140	4,8	60	75	750
0838 748 160	4,8	70	105	750
0838 748 180	4,8	80	120	750
0838 748 200	4,8	90	120	750
0838 748 220	4,8	100	120	750
0838 748 240	4,8	120	120	750



Technické údaje	Použitie do:	Podložka	Potrebná dĺžka
Bi-metall, skrutka, 6-hranná hlava SW8, redukovaný vrtak Povrch: pozinkovaný	Profilový krycí plech do 2 x 1,25 mm	Kovová: (strana 1.52)	Izolácia + min 20 mm

SKRUTKA TRPB

0838 045 ...



MAGNITM
SILVER



Oceľ

≥ 0,88 - max 2 x 1,25 mm

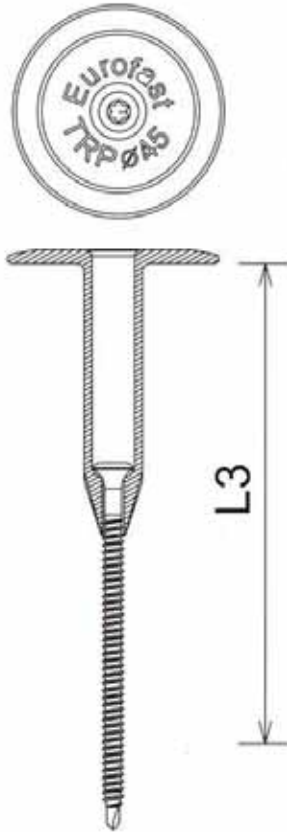

Art.	∅	L	∅ skrutky	L skrutky	L3	Balenie
0838 045 040	45	30	4,8	50	44	250
0838 045 050	45	30	4,8	60	54	250
0838 045 060	45	30	4,8	70	64	250
0838 045 070	45	30	4,8	80	74	250
0838 045 080	45	60	4,8	60	84	250
0838 045 090	45	60	4,8	70	94	250
0838 045 100	45	60	4,8	80	104	250
0838 045 110	45	60	4,8	90	114	250
0838 045 120	45	90	4,8	70	124	250
0838 045 130	45	90	4,8	80	134	250
0838 045 140	45	90	4,8	90	144	250
0838 045 150	45	120	4,8	70	154	250
0838 045 160	45	120	4,8	80	164	250
0838 045 170	45	120	4,8	90	174	250
0838 045 180	45	150	4,8	70	184	250
0838 045 190	45	150	4,8	80	194	250
0838 045 200	45	150	4,8	90	204	250
0838 045 210	45	150	4,8	100	214	250
0838 045 220	45	150	4,8	110	224	250
0838 045 230	45	150	4,8	120	234	250
0838 045 240	45	150	4,8	130	244	250
0838 045 250	45	150	4,8	140	254	250
0838 045 260	45	150	4,8	150	264	250
0838 045 290	45	150	4,8	180	294	250
0838 045 320	45	150	4,8	210	324	250
0838 045 350	45	150	4,8	240	354	250
0838 045 370	45	150	4,8	260	374	250
0838 045 390	45	150	4,8	280	394	250
0838 045 410	45	150	4,8	300	414	250

Technické údaje	Použitie do:	Podložka	Potrebná dĺžka
Skrutka s predmontovanou teleskop. podložkou Podložka: Polyamid PA6 Skrutka: trubková hlava, TX25, redukovaný vrták Povrch: Magni-Silver, min.15 cyklov Kesternich testu podľa DIN 50018 S2, OL	Profilový krycí plech do 2 x 1,25 mm		Izolácia = L3

SKRUTKA TRPBG

0838 445 ...



MAGNITM
SILVER



Oceľ

≥ 0,88 - max 2 x 1,25 mm

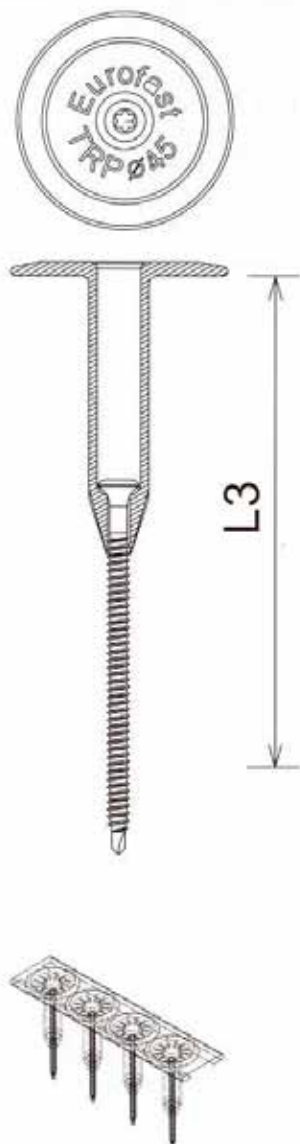

Art.	∅	L	∅ skrutky	L skrutky	L3	Balenie
0838 445 040	45	30	4,8	50	44	1000
0838 445 050	45	30	4,8	60	54	1000
0838 445 060	45	30	4,8	70	64	1000
0838 445 070	45	30	4,8	80	74	1000
0838 445 080	45	60	4,8	60	84	1000
0838 445 090	45	60	4,8	70	94	1000
0838 445 100	45	60	4,8	80	104	1000
0838 445 110	45	60	4,8	90	114	1000
0838 445 120	45	90	4,8	70	124	1000
0838 445 130	45	90	4,8	80	134	1000
0838 445 140	45	90	4,8	90	144	1000
0838 445 150	45	120	4,8	70	154	1000
0838 445 160	45	120	4,8	80	164	1000
0838 445 170	45	120	4,8	90	174	750
0838 445 180	45	150	4,8	70	184	750
0838 445 190	45	150	4,8	80	194	750
0838 445 200	45	150	4,8	90	204	750
0838 445 210	45	150	4,8	100	214	750
0838 445 220	45	150	4,8	110	224	750
0838 445 230	45	150	4,8	120	234	750
0838 445 240	45	150	4,8	130	244	600
0838 445 250	45	150	4,8	140	254	600
0838 445 260	45	150	4,8	150	264	600

Technické údaje	Použitie do:	Podložka	Potrebná dĺžka
Skrutka s predmontovanou teleskop. podložkou Podložka: Polyamid PA6 Skrutka: trubková hlava, TX25, redukovaný vrták Povrch: Magni-Silver, min. 15 cyklov Kesternich testu podľa DIN 50018 S2, OL	Profilový krycí plech do 2 x 1,25 mm		Izolácia = L3

SKRUTKA EDS-H

0838 150 ...



MAGNITM
SILVER

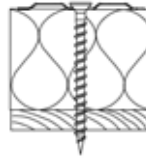

Drevo

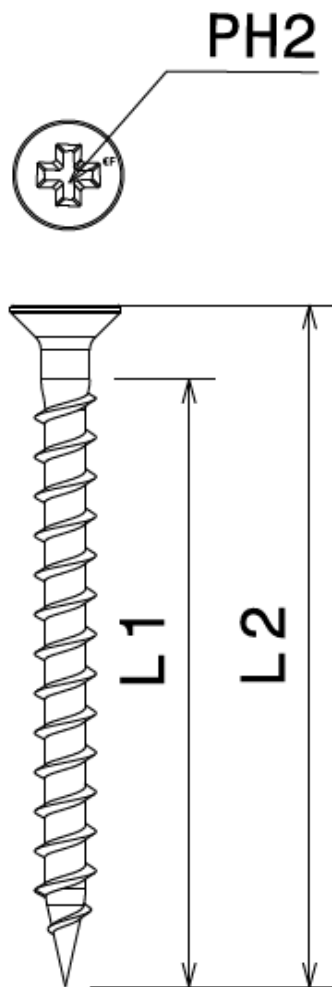

Art.	ø	L1	L2	Balenie
0838 150 020	5,0	20	14	1000
0838 150 025	5,0	25	19	1000
0838 150 030	5,0	30	24	1000
0838 150 035	5,0	35	29	1000
0838 150 040	5,0	40	34	1000
0838 150 045	5,0	45	39	1000
0838 150 055	5,0	55	49	1000
0838 150 065	5,0	65	49	1000
0838 150 075	5,0	75	49	500
0838 150 095	5,0	95	49	500
0838 150 120	5,0	120	49	500

Technické údaje	Použitie do:	Podložka	Potrebná dĺžka
Skrutka, trubková hlava, PH2, tvrdý hrot Povrch: Magni-Silver, min.15 cyklov Kesternich testu podľa DIN 50018 S2, OL	Drevo	Kovová: (strana 1.50/1.51) Plastová: (strana 1.53/1.52)	Izolácia + hrúbka dreva (min. 18 mm)

SKRUTKA DAMPH

0838 154 ...



MAGNI™
SILVER

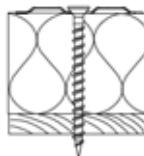

Drevo

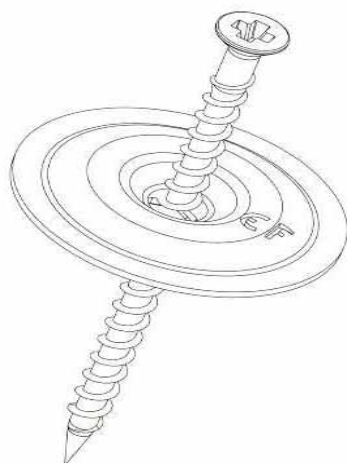

Art.	∅	L1	L2	Balenie
0838 154 020	5,0	20	14	250
0838 154 025	5,0	25	19	250
0838 154 030	5,0	30	24	250
0838 154 035	5,0	35	29	250
0838 154 040	5,0	40	34	250
0838 154 045	5,0	45	39	250
0838 154 055	5,0	55	49	250
0838 154 065	5,0	65	49	250
0838 154 075	5,0	75	49	250
0838 154 095	5,0	95	49	250
0838 154 120	5,0	120	49	250



Art.

0838 150 1

Technické údaje	Použitie do:	Podložka	Potrebná dĺžka
Skrutka s predmontovanou podložkou Podložka: ALUZINC 40 mm Skrutka: trubková hlava, PH2, tvrdý hrot Povrch: Magni-Silver, min. 15 cyklov Kesternich testu podľa DIN 50018 S2, OL	Drevo		Izolácia + hrúbka dreva (min. 18 mm) V kombinácii s magnetickým nastavcom (Art. 0838 150 1)

SKRUTKA GBS

0838 060 ...



MAGNITM
SILVER

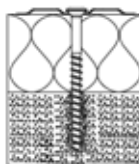

Porobetón

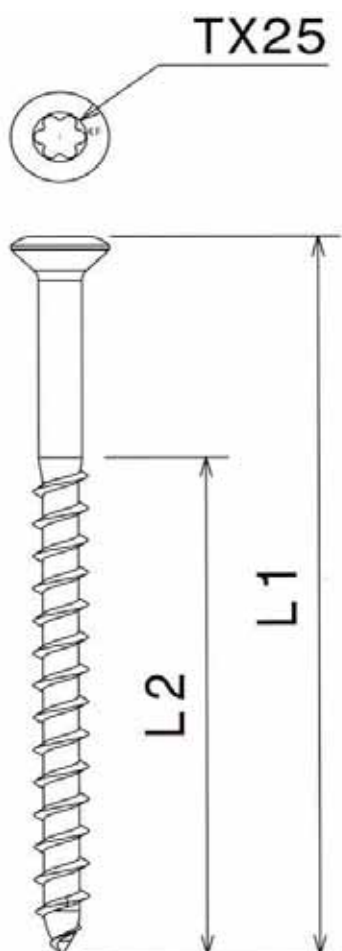

Art.	ø	L1	L2	Balenie
0838 060 060	6,0	60	45	500
0838 060 070	6,0	70	50	500
0838 060 080	6,0	80	70	500
0838 060 090	6,0	90	80	500
0838 060 100	6,0	100	80	500
0838 060 110	6,0	110	80	500
0838 060 120	6,0	120	80	500
0838 060 130	6,0	130	80	500
0838 060 140	6,0	140	80	500
0838 060 160	6,0	160	80	500
0838 060 180	6,0	180	80	500
0838 060 200	6,0	200	80	500

Technické údaje	Použitie do:	Podložka	Potrebná dĺžka
Skrutka, trubková hlava, TX25, tvrdý hrot Povrch: Magni-Silver, min.15 cyklov Kesternich testu podľa DIN 50018 S2, OL	Porobetón	Kovová: (Strana 1.50/1.51) Plastová: (Strana 1.53/1.54)	Izolácia: drevo: + min. 20 mm porobetón: + min. 55 mm pomaly zaskrutkovať

KLINEC ISPC

0838 050 ...

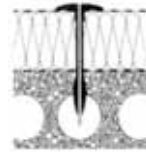

Betón

POLYAMIDE PA 6

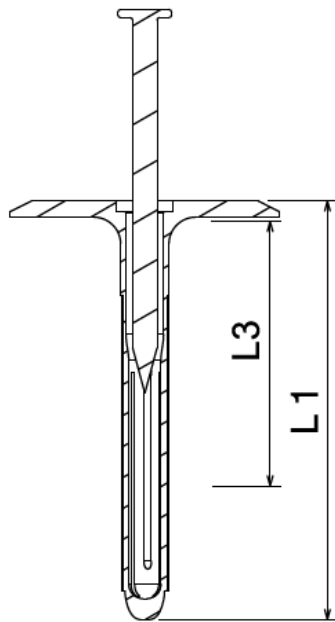

Art.	φ	L1	L3	Balenie
0838 050 045	50 / 8,0	45	0 - 10	250
0838 050 075	50 / 8,0	75	11 - 40	250
0838 050 095	50 / 8,0	95	41 - 60	250
0838 050 115	50 / 8,0	115	61 - 80	250
0838 050 135	50 / 8,0	135	81 - 100	250
0838 050 155	50 / 8,0	155	101 - 120	250
0838 050 175	50 / 8,0	175	121 - 140	250
0838 050 195	50 / 8,0	195	141 - 160	250
0838 050 215	50 / 8,0	215	161 - 180	250
0838 050 245	50 / 8,0	245	181 - 210	125
0838 050 280	50 / 8,0	280	211 - 245	125
0838 050 300	50 / 8,0	300	246 - 265	125
0838 050 330	50 / 8,0	330	266 - 295	125
0838 050 350	50 / 8,0	350	296 - 315	125
0838 050 380	50 / 8,0	380	316 - 345	125
0838 050 410	50 / 8,0	410	346 - 375	125

Art.	φ	Mat.	Otvor	Balenie
0838 050 700	70	0,5	12	250



Technické údaje	Použitie do:	Podložka	Potrebná dĺžka
Predmontovaný teleskop.podložka s klincom Podložka: Polyamid PA6 Klinec: plochá hlava Povrch: Crapal-zinok / 15 cyklov Kesternich testu podľa DIN 50018 S2, OL	Beton	Kovová: 0838 050 700	Izolácia = L3 Predvrtáť s φ 8 mm

SKRUTKA EFHD

0838 163 ...



**MAGNI™
SILVER**

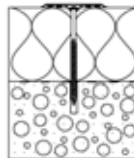

Betón

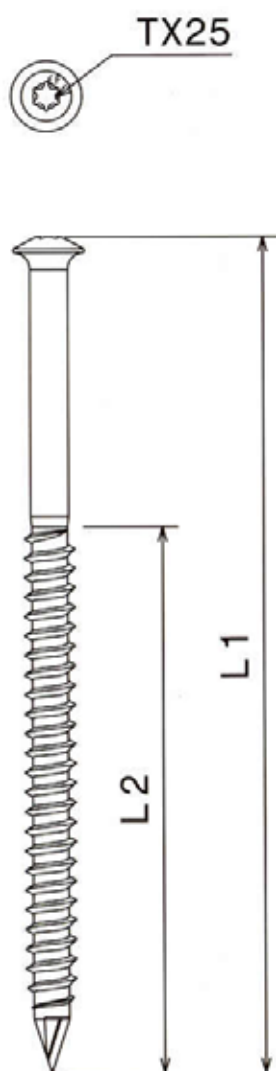

Art.	ø	L1	L2	Balenie
0838 163 060	6,3	60	55	500
0838 163 070	6,3	70	60	500
0838 163 080	6,3	80	60	500
0838 163 100	6,3	100	70	500
0838 163 130	6,3	130	70	500
0838 163 160	6,3	160	70	500
0838 163 200	6,3	200	70	500
0838 163 250	6,3	250	70	500
0838 163 300	6,3	300	70	500

Technické údaje	Použitie do:	Podložka	Potrebná dĺžka
Skrutka, trubková hlava, TX25, vrták-RICOH Povrch: Magni-Silver / 15 cyklov Kesternich testu podľa DIN 50018 S2, OL	Oceľ / Drevo / Betón	Kovová: (Strana 1.50/1.51/ 1.52) Plastová: (Strana 1.53/1.54)	Izolácia: drevo: + min. 20 mm oceľ: + min. 20 mm betón: + min. 35 mm predvrtáť s ø 5 alebo 5,5 mm (v závislosti od tvrdosti betónu)

PODLOŽKA DVL SL

0838

Aluzinc

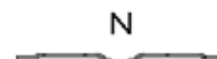
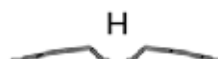

	Art.	Ø	Mat.	Otvor	Balenie
	N 0838 240 100	40	1,0	6,0	1000
	N 0838 250 100	50	1,0	6,3	1000
	D 0838 250 101	50	1,0	6,3	1000
	N 0838 080 401	80 X 40	1,0	6,5	500
	D 0838 080 402	80 X 40	1,0	6,5	500
	H 0838 080 403	80 X 40	1,0	7,0	100
	H 0838 080 404	80 X 40	1,0	7,0	90
	D 0838 080 405	80 X 40	1,0	4,85	700
	0838 087 001	2250 X 30	1,0	4,85/8,0	10
	0838 087 002	2250 X 30	1,0	4,85/8,0	10

Technické údaje	Použitie do:	Podložka	Potrebná dĺžka
Ocelová podložka Povrch: Aluzinc / 15 cyklov Kesternich testu podľa DIN 50018 S2, OL			







PODLOŽKA DVP ML

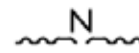
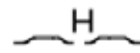
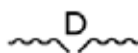

0838

Aluzinc



	Art.	∅	Mat.	Otvor	Balenie
	N 0838 070 051	70	0,5	5,0	1000
	N 0838 070 052	70	0,5	5,0	500
	N 0838 070 053	70	0,5	5,0	500
	D 0838 070 054	70	0,5	5,0	1000
	N 0838 070 070	70	0,7	6,0	1000
	N 0838 070 071	70	0,7	6,0	500
	N 0838 070 072	70	0,7	6,0	500
	D 0838 070 073	70	0,7	6,0	500
	H 0838 070 074	70	0,7	6,0	500
	N 0838 070 075	70	1,0	7,0	500
	D 0838 070 076	70	1,0	7,0	500





Technické údaje	Použitie do:	Podložka	Potrebná dĺžka
Ocelová podložka Povrch: Aluzinc / 15 cyklov Kesternich testu podľa DIN 50018 S2, OL			

PODLOŽKA DVP AUT

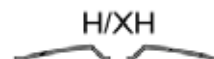
0838

Aluzinc



	Art.	ø	Mat.	Otvor	Balenie
	D 0838 707 001	70 X 70	1,0	7,0	100
	0838 707 003	70 X 70	1,0	4,85	100
	D 0838 707 002	82 X 40	1,0	7,0	100
	0838 707 004	82 X 40	1,0	4,85	100
	H 0838 707 005	82 X 40	1,0	7,0	100
	ZK 0838 080 407	81 X 40	1,0	4,85	90

Technické údaje	Použitie do:	Podložka	Potrebná dĺžka
Ocelová podložka Povrch: Aluzinc / 15 cyklov Kesternich testu podľa DIN 50018 S2, OL			

PODLOŽKA TLK-45



0838 245 ...

POLYPROPYLENE

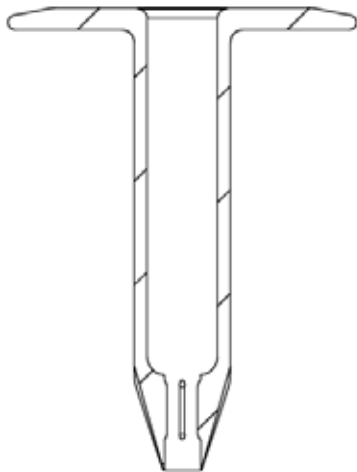

Art.	ø	L1	Balenie
0838 245 035	45	35	500
0838 245 065	45	65	500
0838 245 085	45	85	500
0838 245 105	45	105	500
0838 245 135	45	135	250
0838 245 165	45	165	250
0838 245 185	45	185	250
0838 245 225	45	225	125
0838 245 255	45	255	125
0838 245 285	45	285	125
0838 245 320	45	320	125

Technické údaje	Použitie do:	Podložka	Potrebná dĺžka
Plastová podložka Materiál: Polypropylén			

PODLOŽKA TLK-75

0838 275 ...

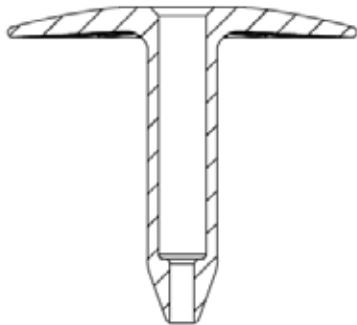
POLYPROPYLENE

Art.	∅	L	Balenie
0838 275 035	75	35	250
0838 275 065	75	65	250
0838 275 085	75	85	250
0838 275 105	75	105	250
0838 275 135	75	135	250
0838 275 165	75	165	250
0838 275 185	75	185	125

Technické údaje	Použitie do:	Podložka	Potrebná dĺžka
Plastová podložka Materiál: Polypropylén			

SKRUTKA OMG RS

0838 355 ...

Factory
Mutual
System
Approved

CR-10



Oceľ

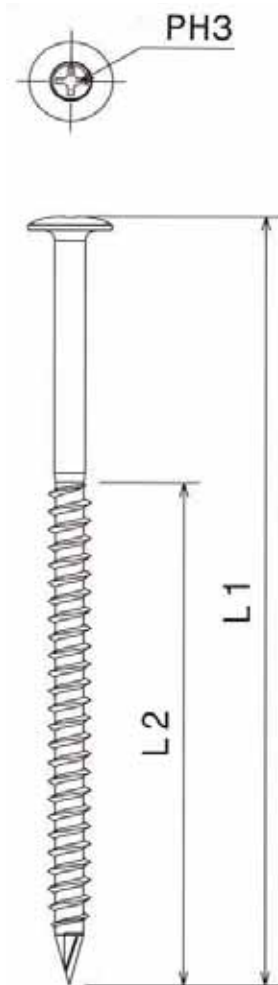

Art.	ø	L1	L2	Balenie
0838 355 040	5,5	40	40	1000
0838 355 055	5,5	55	50	1000
0838 355 075	5,5	75	70	1000
0838 355 075	5,5	85	70	1000
0838 355 095	5,5	95	75	1000
0838 355 115	5,5	115	75	1000
0838 355 125	5,5	125	75	1000
0838 355 150	5,5	150	100	1000
0838 355 175	5,5	175	100	1000
0838 355 200	5,5	200	100	1000

Technické údaje	Použitie do:	Podložka	Potrebná dĺžka
OMG skrutka so šošovkovou hlavou (FM-Approval), PH3, lyžicový vrták. Povrch: CR-10 čierne 30 cyklov Kesternich test DIN 50018 S2, OL	Profilový krycí plech 2 x 1,25 mm	Kovová: (Strana 1.50/1.51/1.52/1.65) Plastová: (Strana 1-65)	Izolácia + min. 20 mm

SKRUTKA OMG HD

0838 160 ...

Factory
Mutual
System
Approved

CR-10



Univerzálna

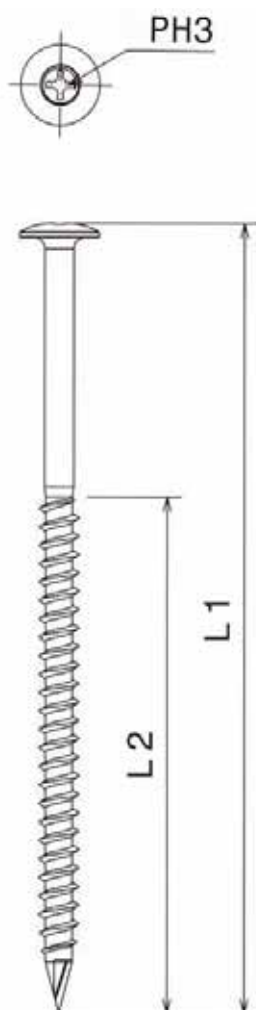

Art.	ø	L1	L2	Balenie
0838 160 030	6,0	30	30	1000
0838 160 045	6,0	45	40	1000
0838 160 055	6,0	55	50	1000
0838 160 075	6,0	75	70	1000
0838 160 083	6,0	83	70	1000
0838 160 095	6,0	95	70	1000
0838 160 115	6,0	115	70	1000
0838 160 125	6,0	125	100	1000
0838 160 150	6,0	150	100	1000
0838 160 175	6,0	175	100	500
0838 160 200	6,0	200	100	500
0838 160 225	6,0	225	125	500
0838 160 250	6,0	250	125	500
0838 160 275	6,0	275	125	500
0838 160 300	6,0	300	125	500
0838 160 330	6,0	330	125	500
0838 160 350	6,0	350	125	500
0838 160 405	6,0	405	125	250
0838 160 460	6,0	460	125	250
0838 160 510	6,0	510	125	250
0838 160 560	6,0	560	125	250
0838 160 610	6,0	610	125	250

Technické údaje	Použitie do:	Podložka	Potrebná dĺžka
OMG skrutka so šošovkovou hlavou (FM-Approval), PH3, lyžicový vrták. Povrch: CR-10 čierne 30 cyklov Kesternich test DIN 50018 S2, OL	Profilový krycí plech 2 x 1,25 mm	Kovová: (Strana 1.50/1.51/ 1.52/1.65) Plastová: (Strana 1.65)	Izolácia: drevo: + min. 20 mm porobetón: + min. 55 mm betón: + min. 35 mm

SKRUTKA OMG XHD

0838 167 ...

Factory
Mutual
System
Approved

CR-10

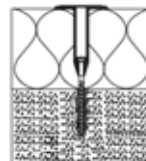

Univerzálna

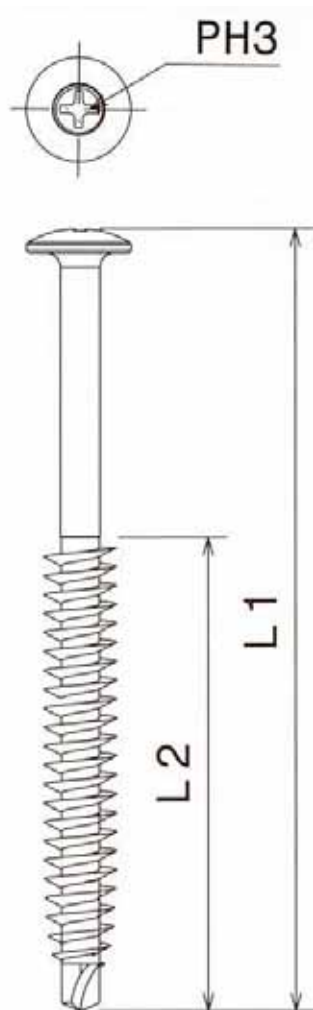

Art.	ø	L1	L2	Balenie
0838 167 032	6,7	32	30	1000
0838 167 050	6,7	50	50	1000
0838 167 075	6,7	75	70	1000
0838 167 100	6,7	100	70	1000
0838 167 125	6,7	125	100	500
0838 167 150	6,7	150	100	500
0838 167 175	6,7	175	100	500
0838 167 200	6,7	200	100	500
0838 167 225	6,7	225	100	500
0838 167 250	6,7	250	100	500
0838 167 275	6,7	275	100	500
0838 167 300	6,7	300	100	500
0838 167 350	6,7	350	100	500
0838 167 410	6,7	410	100	250
0838 167 460	6,7	460	100	250
0838 167 510	6,7	510	100	250
0838 167 560	6,7	560	100	125

Technické údaje	Použitie do:	Podložka	Potrebná dĺžka
OMG skrutka so šošovkovou hlavou (FM-Approval), PH3, redukčný vrták. Povrch: CR-10 čierne 30 cyklov Kesternich test DIN 50018 S2, OL	Profilový krycí plech 2 x 1,25 mm	Kovová: (Strana 1.50/1.51/1.52/1.65) Plastová: (Strana 1.65)	Izolácia: Durisol: + min. 20 mm pričom vrchná vrstna oceľ-hliník-sandwichpanel: + min. 20 mm predvrtat' s ø 5 alebo 5,5 mm (v závislosti od tvrdosti betonu)

SKRUTKA OMG RND

0838 263 ...

MAGNI™
SILVER

Betón

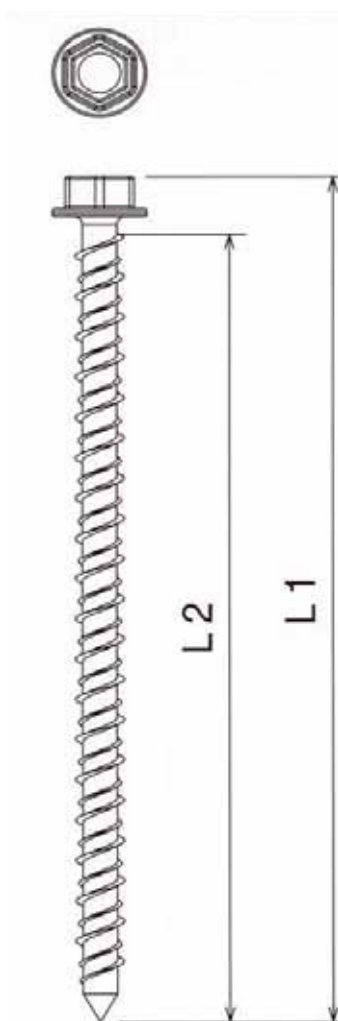

Art.	ø	L1	L2	Balenie
0838 263 032	6,3	32	30	1000
0838 263 041	6,3	41	40	1000
0838 263 057	6,3	57	50	1000
0838 263 070	6,3	70	60	1000
0838 263 081	6,3	81	60	1000
0838 263 094	6,3	94	60	1000
0838 263 102	6,3	102	60	1000
0838 263 127	6,3	127	60	1000
0838 263 140	6,3	140	60	1000
0838 263 152	6,3	152	60	500
0838 263 178	6,3	178	60	500
0838 263 203	6,3	203	60	500
0838 263 229	6,3	229	60	500
0838 263 254	6,3	254	60	500
0838 263 278	6,3	278	60	500
0838 263 305	6,3	305	60	500

Technické údaje	Použitie do:	Podložka	Potrebná dĺžka
OMG skrutka do betónu so šesťhrannou hlavou SW8 a diamant. vrtákom. Povrch: Magni-Silver 15 cyklov Kesternich test DIN 50018 S2, OL	Betón	Kovová: (Strana 1.50/1.51/1.52)	Izolácia + min 35 mm. Predvŕtať s ø 5 alebo 5,5 mm (v závislosti od tvrdosti betónu)

KLINEC OMG CD-10

0838 255 ...

Factory
Mutual
System
Approved

CR-10

Betón

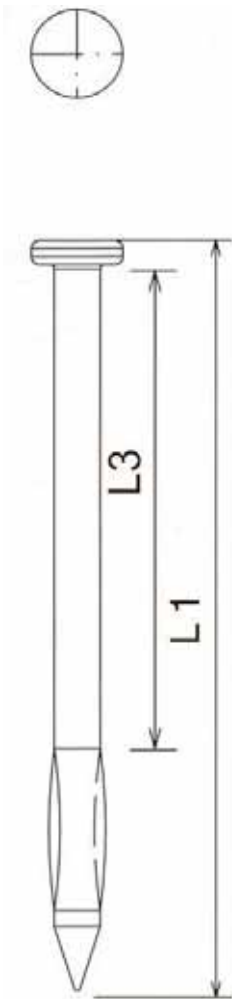





Art.	ø	L1	L3	Balenie
0838 255 050	5,5	51	25	500
0838 255 065	5,5	65	40	500
0838 255 075	5,5	75	50	500
0838 255 090	5,5	90	65	500
0838 255 100	5,5	100	75	500
0838 255 115	5,5	115	90	500
0838 255 125	5,5	125	100	500
0838 255 140	5,5	140	115	500
0838 255 150	5,5	150	125	500
0838 255 175	5,5	175	150	500
0838 255 200	5,5	200	175	500
0838 255 230	5,5	230	205	250
0838 255 250	5,5	250	225	250
0838 255 275	5,5	275	250	25
0838 255 300	5,5	300	275	250

Technické údaje	Použitie do:	Podložka	Potrebná dĺžka
OMG Kliniec do betónu, tvrdený hrot (FM-Approval), plochá hlava, Povrch: CR-10 čierny, 30 cyklov Kesternich test DIN 50018 S2, OL	Betón	Kovová: (Strana 1.50/1.51/ 1.52/1.65) Plastová: (Strana 1.65)	Izolácia = L3 Betón: + min.25 mm Predvŕtať s ø 5,5 mm (v závislosti od tvrdosti betonu)

PODLOŽKA OMG DVP

0838



	Art.	Mat.	∅	L1	Otvor	Balenie
	0838 051 001	Oceľ	51		6,5	500
	0838 051 002	Oceľ	51	0,7	6,5	1000
	0838 051 003	Oceľ	51	0,7	6,8	1000
	0838 051 004	Plast	5,1	1,2	6,8	1000
	0838 063 001	Oceľ	63	0,7	6,8	1000

OMG GYPTEC

0838 018 ...

OSD

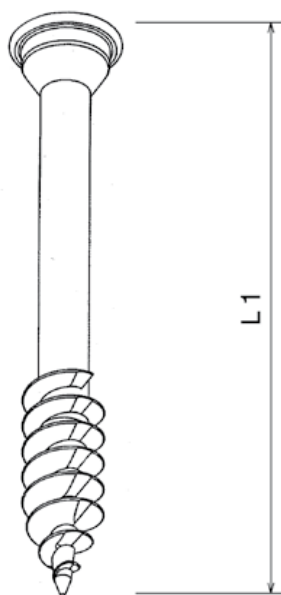

Art.	ø	L1	Balenie
0838 018 063	18	63	500
0838 018 076	18	76	500
0838 018 102	18	102	500
0838 018 127	18	127	500
0838 018 152	18	152	500
0838 018 178	18	178	500
0838 018 203	18	203	500

Art.

0838 018 000

Nadstavec OMG GYPTEC

Technické údaje	Použitie do:	Podložka	Potrebná dĺžka
OMG GYPTEC Plastová skrutka (Náhon R2)	OSD	Kovová: 0838 051 001 (Strana 1.65)	hrúbka OSD + min.50 mm

VRTAK SDS-PLUS

0838

Príklepový vrták SDS









Art.	∅	L1	L2		
0838 650 210	5,0	210	150		
0838 650 260	5,0	260	200		
0838 650 310	5,0	310	250		
0838 650 400	5,0	410	350		
0838 655 160	5,5	160	100		
0838 655 210	5,5	210	150		
0838 655 260	5,5	260	200		
0838 655 310	5,5	310	250		
0838 655 350	5,5	350	300		
0838 655 410	5,5	410	350		
0838 655 600	5,5	600	540		
0838 660 460	6,0	460	400		
0838 680 310	8,0	310	250		
0838 680 400	8,0	400	340		
0838 610 310	10,0	310	250		
0838 612 310	12,0	310	250		

PRÍSLUŠENSTVO

0838

Bity
Nadstavce

	Art.		L		
	0838 002 150	PH 2	150		
	0838 002 250	PH 2	250		
	0838 003 150	PH 3	150		
	0838 003 250	PH 3	250		
	0838 125 150	TX 25	150		
	0838 125 250	TX 25	250		
	0838 600 1			PH 3	
	0838 600 2			PH 2	
	0838 600 13				
	0838 101	1/4"			
	0838 200 000	PH2	50	M6	

KATALÓG

KOTVIACE PRVKY NA PLOCHÉ STRECHY A OPLÁŠTENIA STAVIEB

Würth spol. s r.o.
Pribylinská 2
SK - 832 55 Bratislava 3
T 02 / 4920 1211
F 02 / 4920 1299
e-mail: wurth@wurth.sk
www.wurth.sk

© 2011 · Würth s.r.o., Bratislava · Všetky práva vyhradené.

